



AQUATRAX

A unique cleaning machine for athletic track surfaces



AQUATRAX combines pressure washing which loosens dirt and algae retained on or in the surface, with a unique vacuum extraction system which removes virtually all the dirty water to a tank on the machine so that the contaminants held in the water are not returned to the surface.

DESIGNED AND BUILT BY CHARLES LAWRENCE INTERNATIONAL LTD

Because it physically removes contamination - unlike conventional pressure-washing, which merely dislodges it - **AQUATRAX** provides a highly effective method of restoring the appearance, foot grip and (for porous surfaces) the free-draining characteristics of the surface. Line markings are refreshed so repainting is not always required.

The **AQUATRAX** machine has been specially developed to wash contamination from athletics track surfaces and collect it. Compared to conventional high pressure washing the process is gentle, thorough and highly efficient.

- Optimally directed low-pressure water jets deliver only clean, cold water—no chemicals, no abrasion.
- Contamination is removed, not re-distributed.
- Low ground pressure vehicle cannot damage the track surface.

The 74 hp diesel engine drives the water pumps and the high-capacity vacuum system.

Why is it necessary to use **AQUATRAX**?

All outdoor sports surfaces are subject to pollution which is continually washed down by rain, blown by the wind, conveyed by birds and insects and carried on players' footwear. This gradually accumulates on or in the surface, detracting from the appearance and making markings difficult to see. Pollution also hinders the drainage of porous materials and may make the surface slippery, creating a Health & Safety risk and the possibility of claims from users.

Specification

Vehicle:	2082 mm 5700 mm 2220 mm
Engine:	Kubota Diesel 74 bhp Transmission 4 speed with reversing gearbox Speed 2.7– 32 km/h 4 wheel drive
Tank capacity:	Clean water 1700L nominal Dirty water 1900L nominal
Weight unladen:	4.260 kg
Max laden weight:	5990 kg (clean water)
Tyres:	Low ground pressure

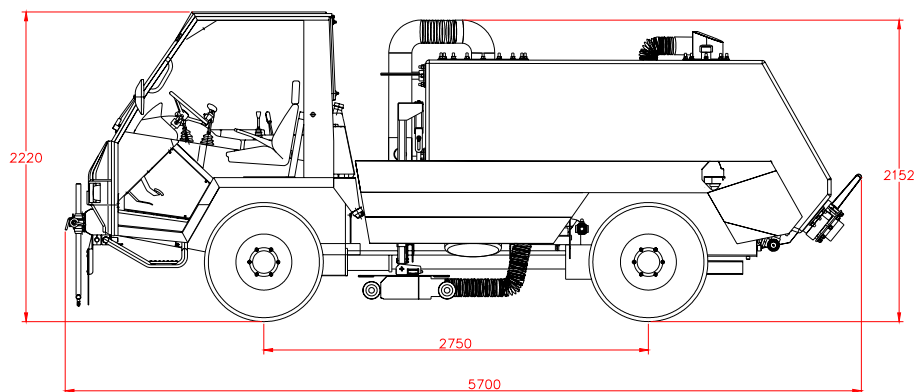

Charles Lawrence International Ltd

Jessop Way, Newark, Nottinghamshire NG24 2ER, England

Tel: + 44 (0)1636 610680 Fax: + 44 (0)1636 613259 E-mail: international@clgplc.co.uk Web site: www.clgplc.co.uk