

Beaver B1000

Rejuvenating synthetic grass surfaces

Innovative machinery and equipment



The Beaver B1000 is a smaller, more compact version of the larger B2000 Multi especially designed for entering tennis court type areas via the single hand gate without the need for dismantling the fencing. The B1000 comes as an attachment to the Power Frame which also offers other added value attachments such as oscillating and rotary brushes for complete maintenance of synthetic turf surfaces.

The machine is market leading technology which has been proven on sand filled turf at hundreds of sports surfaces worldwide

It directs compressed air through the deepest pile to the carpet backing, de-compacting and removing the infill. The Beaver 1000 will extract sand infill to any specified depth - from 5mm down to the carpet backing, if required. The powerful action untangles pile fibres, leaving them upright and in position to receive replacement infill materials.

The machine is simple and straightforward to operate, powered by a 14Hp (10kw) Kubota diesel tractor fitted with the power frame.

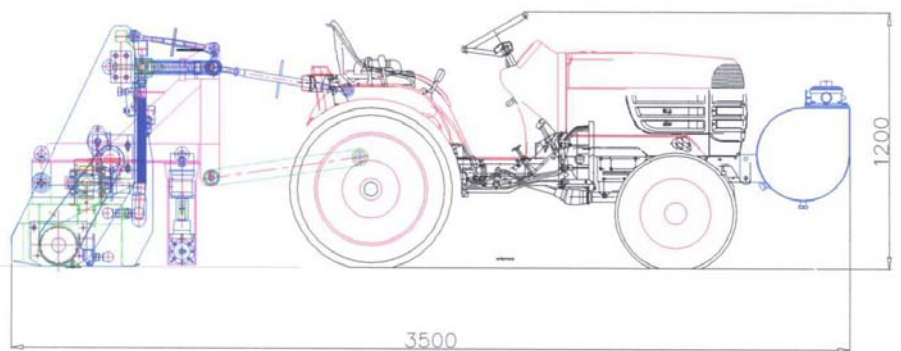
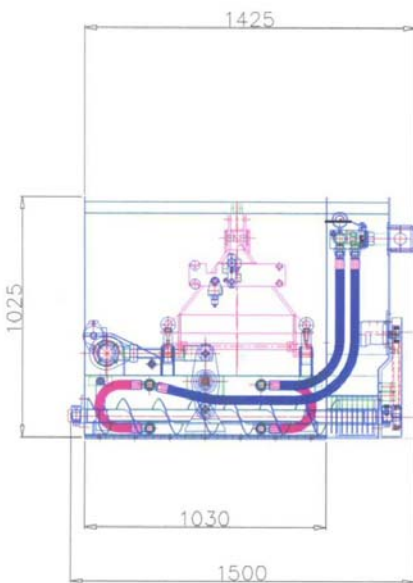

Specification

Power:	14 Hp (10Kw)	Tyres:	Option of Turf / Agricultural
Air Supply:	Via portable compressor - 800kg	Front Axle	120 kg
Main Hydraulic Supply:	24 litres / min	Rear Axle	800 kg
Power Unit:	Kubota B1410		

We reserve the right to alter specifications and add to, or withdraw, items available without notice

Charles Lawrence International is the leading name in construction and maintenance equipment for synthetic sport and play surfaces. Innovative engineering solutions, reliable machines and full back up service are integral to the company's success.

Charles Lawrence International operates in three separate but inter-related markets. In addition to the supply of machines for creating and maintaining synthetic sport and play surfaces, it is market leader in the production of recycled rubber granulate and manufactures recycling plant and equipment for world markets.

Charles Lawrence International Ltd

Jessop Way, Newark, Nottinghamshire, NG24 2ER, ENGLAND

Tel: + 44 (0) 1636 642460 Fax: + 44 (0) 1636 613259

Email: info@pitchmachinery.co.uk

Websites: www.pitchmachinery.co.uk www.clgplc.co.uk

